

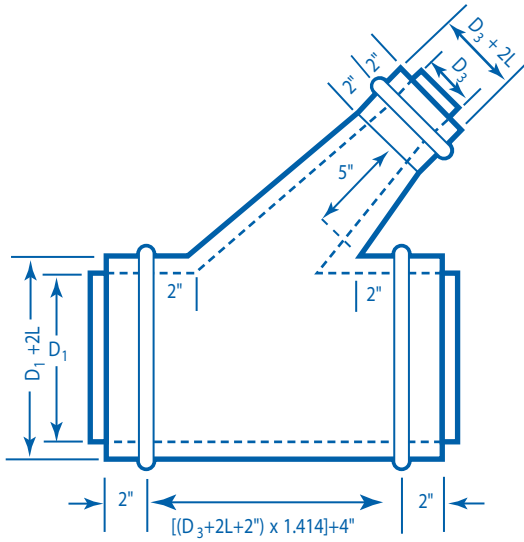

Conical Laterals

Conical Lateral 45°



Reducing Conical Lateral 45°

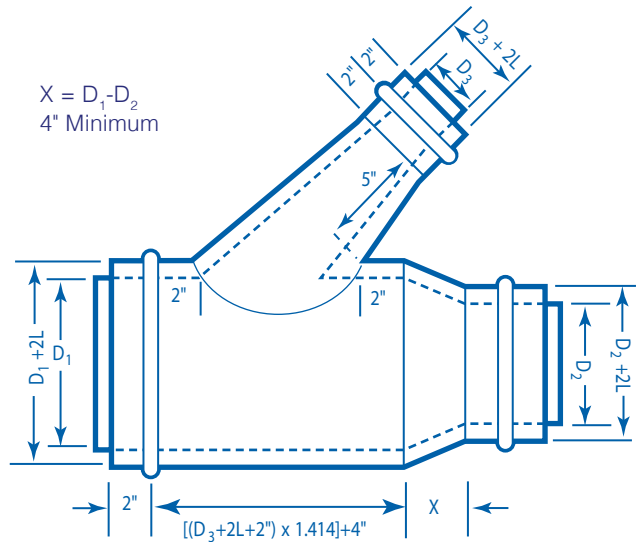

Conical Lateral 45° Cross

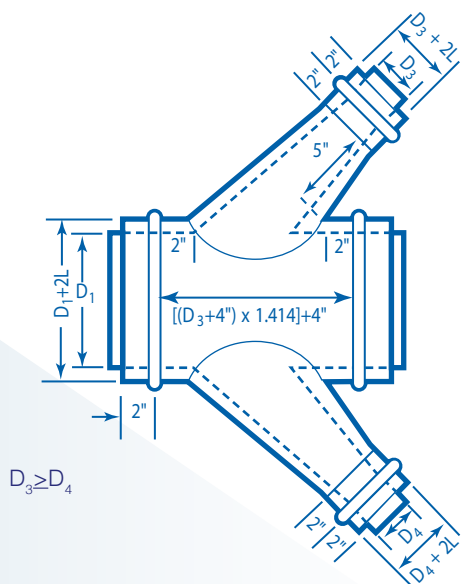

Reducing Conical 45° Lateral Cross

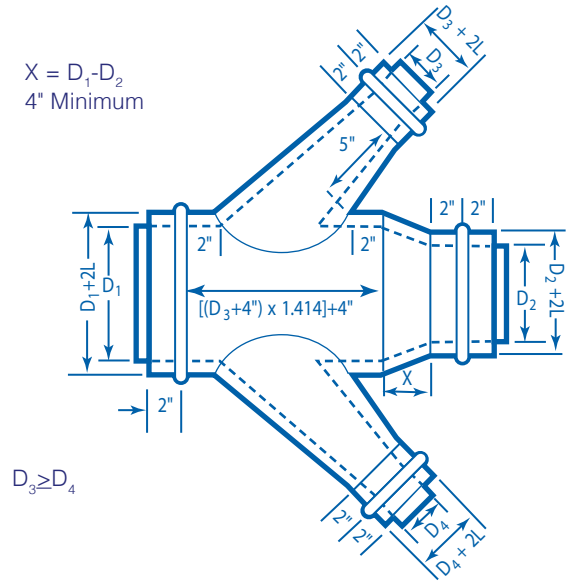



Concentric Reducer

$$X = D_1 - D_2$$

4" Minimum

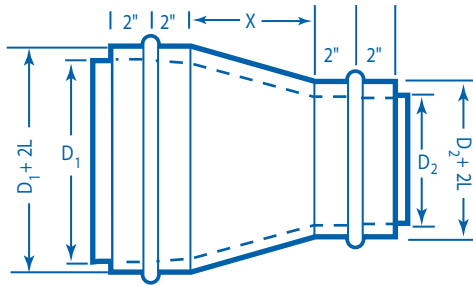

Eccentric Reducer

$$X = 2 [D_1 - D_2]$$

4" Minimum

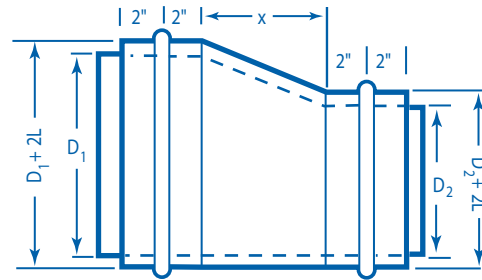

Pipe Couplings

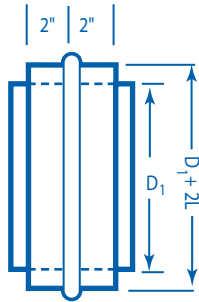

Fitting Couplings

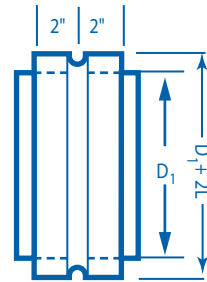

Insulation Stop

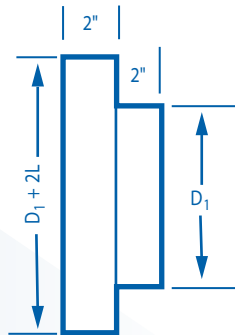

End Cap

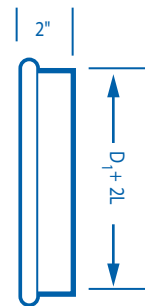



30° Offset

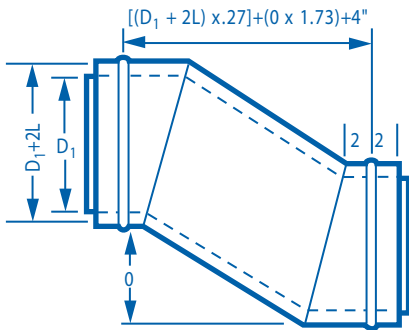

Rectangle to Round

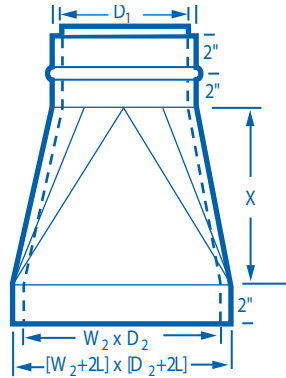

Wye Branch

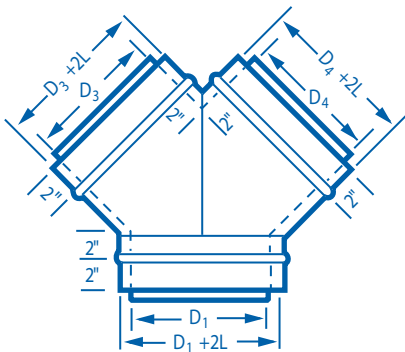

Reducing Wye Branch

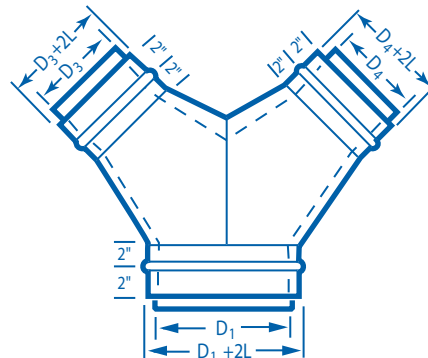

Bullhead Tee

With or without vanes

D ₁	# of Vanes
3-7	1
8-10	3
12-60	5
> 60	max spacing = 12"

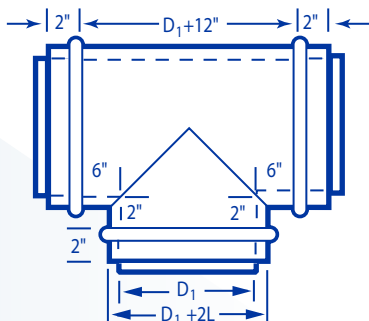

Reducing Bullhead Tee

With or without vanes

D ₁	# of Vanes
3-7	1
8-10	3
12-60	5
> 60	max spacing = 12"

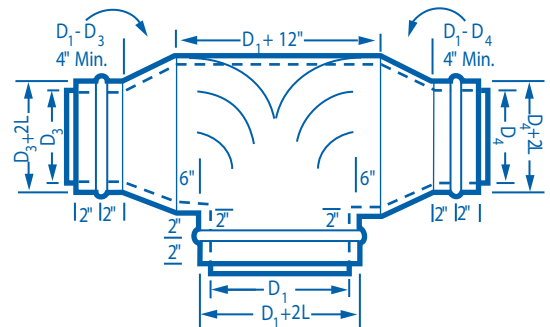



Rectangular Access Section

Also available as shop-installed SRTA or field-installed accessory FRTA.

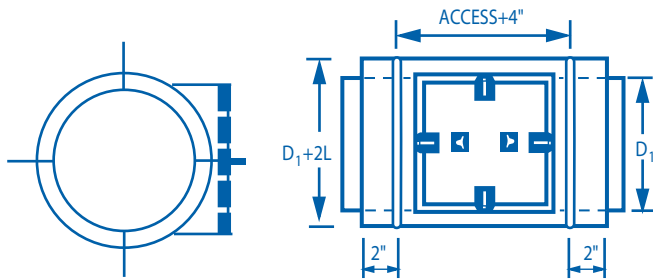

D ₁	Access Size
8" to 12"	8" x 8"
13" to 17"	12" x 12"
18" and over	18" x 18"

Negative and positive pressure.

Spun Bellmouth

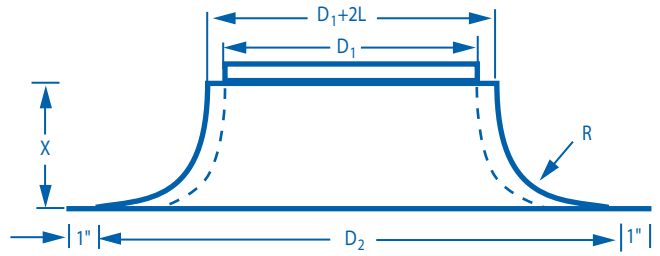

STANDARD BELLMOUTH

D ₁	D ₂	L	R
13"	19"	4"	3"
14"	21"	4"	3"
15"	24"	5"	4"
16"	26"	5"	4"
17"	25"	5"	4"
18"	26"	5"	4"
20"	28"	5"	4"
21"	29"	5"	4"
22"	32"	6"	5"
23"	33"	6"	5"
24"	34"	6"	5"
26"	38"	7"	6"
28"	40"	7"	6"
30"	42"	7"	6"
32"	46"	8"	7"
34"	48"	8"	7"
36"	50"	8"	7"
38"	52"	8"	7"
40"	56"	9"	8"
42"	58"	9"	8"
44"	60"	9"	8"
46"	62"	9"	8"
48"	64"	9"	8"

SHORT RADIUS BELLMOUTH

D ₁	D ₂	L
12"	14"	3½"
14"	16"	3½"
16"	18"	3½"
18"	20"	3½"
20"	22"	3½"
22"	24"	3½"
24"	26"	3½"
26"	28"	3½"
28"	30"	3½"
30"	32"	3½"
32"	34"	3½"
34"	36"	3½"
36"	38"	3½"
38"	40"	3½"
40"	42"	3½"
42"	44"	3½"
44"	46"	3½"
46"	48"	3½"
48"	40"	3½"
50"	52"	3½"
52"	54"	3½"
54"	56"	3½"
56"	58"	3½"
58"	60"	3½"
60"	62"	3½"

Pressed Bellmouth

Galvanized only

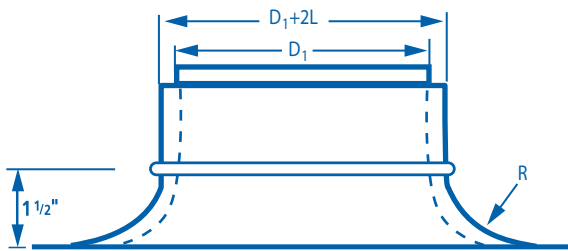

D ₁	R
4"	.394"
5"	.472"
6"	.787"
7"	1.0"
8"	1.0"
9"	1.0"
10"	1.0"
12"	1.0"



Accessories

Shop Installed / Field Installed

Shop/Field Installed Tap

Standard flange is 1/2".
2" flange is also available.

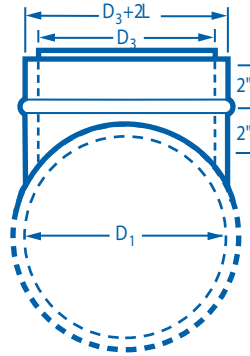

Shop/Field Installed Conical Tap

Standard flange is 1/2".
2" flange is also available.

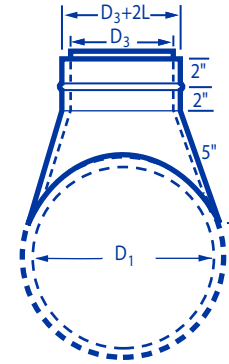

Shop/Field Installed Lateral Tap

Standard flange is 1/2".
2" flange is also available.

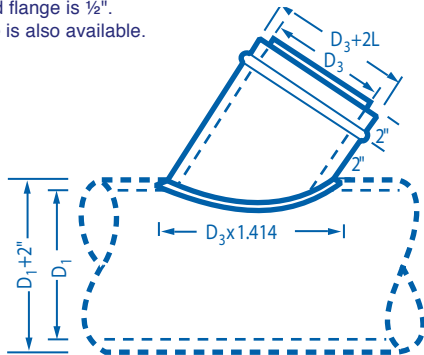

Shop/Field Installed Combination Tap

Standard flange is 1/2".
2" flange is also available.

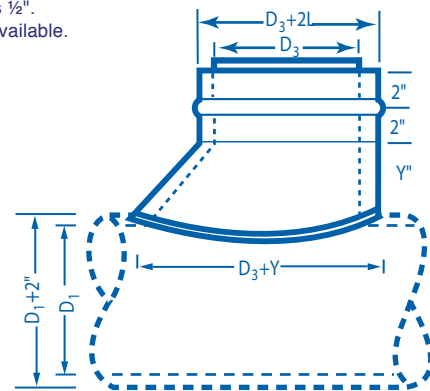

Shop/Field Rectangle on Round

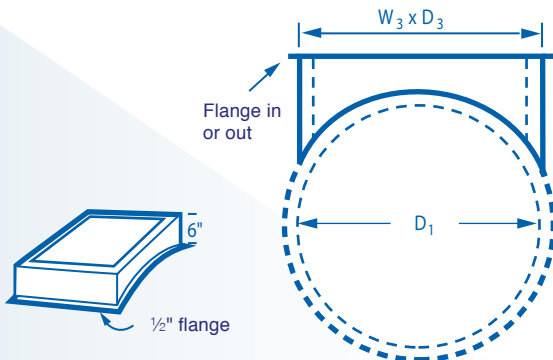

Field Installed Standard Door

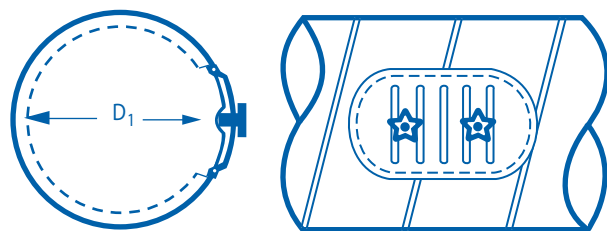



DUAL WALL SLIP FIT

The inner and outer collars of fittings are sized to slip into, and should be used with, Corken Steel spiral duct. The inner collar projects beyond the outer collar. This permits the inner collar to be started into the inner liner of the spiral duct in a manner similar to the single wall technique. A tight fit is necessary to minimize friction loss and to promote proper sealing. Care should be taken during handling and installation to avoid dents and distortions that can cause improper fit or difficult installation.

1. Bring the bottom of the inner fitting collar into the inner spiral duct at a slight angle.
2. Work the rest of the inner collar into the spiral duct.
3. When the inner collar is fully inserted, start the outer collar in the same manner.
4. Carefully work the rest of the collar into the spiral duct until approximately one inch of the collar remains exposed between the end of the spiral duct and the stop bead of the fitting collar. Do not use a screwdriver or knife to help make the connection. Apply pressure with the heel of your hand or with your fist to help slip the fitting into the duct.
5. Apply duct sealer to this exposed area.
6. Push the fitting into the spiral duct until the stop bead meets the edge of the spiral duct.
7. Fasten the fitting into the spiral duct with screws per the chart at right. The screws should be evenly spaced around the perimeter of the connection, approximately $\frac{1}{2}$ " back from the stop bead. Placement of the screws should be opposite of each other as demonstrated in the diagram.

FLANGE

Flanges come factory-mounted on fittings and spiral duct. Flanges are standard for all duct 61" in diameter, but are available in smaller sizes. Dual wall flanges attach to both the outer wall and inner wall of the duct, eliminating the need to make an inner connection.

1. Place closed cell neoprene gasket on the face of one of the mating flanges.
2. Push the flanges together keeping the edges of the flanges aligned.
3. Clamp the flanges to help hold them in place.
4. Screw the flanges together with self-tapping screws per the chart at right. The screws should be evenly spaced around the perimeter of the connection. Placement of the screws should be opposite of each other as demonstrated in the diagram.

Installation of Slip Joint Connector

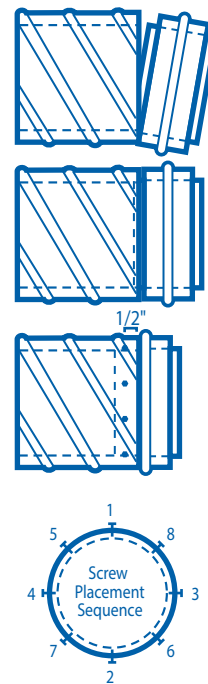

Installation of Flange Connector

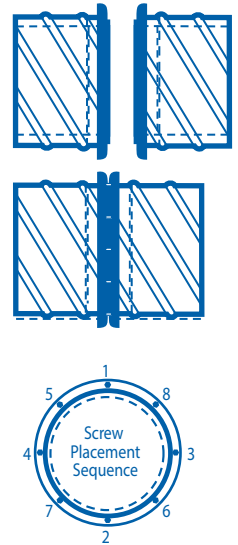

Duct Perimeter Round Equiv.	# of Screws	
	Slip Fit	Flange
4"-9"	3	NA
10"	3	4
12"-16"	3	6
18"-20"	4	8
22"-26"	5	10
28"-30"	6	12
32"-36"	7	14
38"-42"	8	16
44"-46"	9	18
48"-52"	10	20
54"-56"	11	22
58"-60"	12	24
62"-66"	NA	26
68"-72"	NA	28
74"-76"	NA	30
78"-84"	NA	32



Insertion Loss Testing

Insertion loss testing for Double Wall Spiral Pipe was conducted by the Center for Mechanical System Technology at the University of Nevada Las Vegas. Test results for 1" liner and 2" liner are shown below.

Insertion Loss = dB/ft

Dia. in.	LINER THICKNESS = 1"								LINER THICKNESS = 2"							
	Octave Band Center Frequency – Hz								Octave Band Center Frequency – Hz							
	63	125	250	500	1000	2000	4000	8000	63	125	250	500	1000	2000	4000	8000
12	0.07	0.34	1.01	1.75	3.83	3.04	2.06	1.62	0.15	0.52	1.58	2.75	3.83	3.04	2.06	1.62
14	0.07	0.30	0.92	1.67	3.57	2.80	1.99	1.62	0.15	0.47	1.49	2.68	3.57	2.80	1.99	1.62
16	0.06	0.26	0.84	1.61	3.34	2.59	1.93	1.60	0.14	0.43	1.41	2.61	3.34	2.59	1.93	1.60
18	0.06	0.22	0.77	1.54	3.12	2.40	1.87	1.59	0.14	0.40	1.34	2.55	3.12	2.40	1.87	1.59
20	0.05	0.19	0.70	1.48	2.91	2.24	1.82	1.57	0.13	0.37	1.27	2.48	2.91	2.24	1.82	1.57
22	0.05	0.16	0.64	1.42	2.72	2.10	1.78	1.55	0.12	0.34	1.21	2.43	2.72	2.10	1.78	1.55
24	0.04	0.14	0.58	1.37	2.55	1.98	1.74	1.52	0.12	0.31	1.15	2.37	2.55	1.98	1.74	1.52
26	0.04	0.11	0.53	1.31	2.39	1.88	1.70	1.49	0.11	0.29	1.10	2.32	2.39	1.88	1.70	1.49
28	0.03	0.10	0.48	1.26	2.25	1.80	1.66	1.46	0.11	0.27	1.05	2.27	2.25	1.80	1.66	1.46
30	0.03	0.08	0.44	1.21	2.11	1.73	1.63	1.42	0.11	0.25	1.01	2.22	2.11	1.73	1.63	1.42
32	0.02	0.07	0.40	1.17	1.99	1.67	1.60	1.39	0.10	0.24	0.97	2.17	1.99	1.67	1.60	1.39
34	0.02	0.05	0.36	1.12	1.88	1.63	1.58	1.35	0.10	0.23	0.93	2.12	1.88	1.63	1.58	1.35
36	0.01	0.04	0.33	1.07	1.78	1.59	1.55	1.31	0.09	0.22	0.90	2.08	1.78	1.59	1.55	1.31
38	0.01	0.04	0.30	1.03	1.69	1.57	1.53	1.26	0.09	0.21	0.87	2.03	1.69	1.57	1.53	1.26
40	0.01	0.03	0.28	0.99	1.60	1.55	1.50	1.22	0.09	0.20	0.85	1.99	1.60	1.55	1.50	1.22
42	0.00	0.02	0.25	0.94	1.53	1.53	1.48	1.17	0.08	0.20	0.83	1.95	1.53	1.53	1.48	1.17
44	0.00	0.02	0.23	0.90	1.46	1.52	1.45	1.12	0.08	0.19	0.80	1.90	1.46	1.52	1.45	1.12
46	0.00	0.02	0.21	0.85	1.39	1.52	1.43	1.07	0.08	0.19	0.79	1.85	1.39	1.52	1.43	1.07
48	0.00	0.01	0.20	0.80	1.33	1.51	1.40	1.02	0.08	0.19	0.77	1.81	1.33	1.51	1.40	1.02
50	0.00	0.01	0.18	0.75	1.27	1.50	1.38	0.97	0.07	0.19	0.75	1.76	1.27	1.50	1.38	0.97
52	0.00	0.01	0.16	0.71	1.22	1.48	1.35	0.92	0.07	0.19	0.73	1.71	1.22	1.48	1.35	0.92
54	0.00	0.01	0.15	0.65	1.17	1.46	1.31	0.87	0.07	0.18	0.72	1.66	1.17	1.46	1.31	0.87
56	0.00	0.01	0.13	0.60	1.12	1.44	1.28	0.81	0.07	0.18	0.70	1.60	1.12	1.44	1.28	0.81
58	0.00	0.00	0.12	0.54	1.07	1.40	1.24	0.76	0.07	0.18	0.69	1.55	1.07	1.40	1.24	0.76
60	0.00	0.00	0.10	0.48	1.02	1.36	1.20	0.71	0.06	0.18	0.67	1.49	1.02	1.36	1.20	0.71
62	0.00	0.00	0.08	0.42	0.97	1.30	1.15	0.66	0.06	0.17	0.66	1.43	0.97	1.30	1.15	0.66
64	0.00	0.00	0.06	0.36	0.91	1.23	1.10	0.61	0.06	0.17	0.64	1.36	0.91	1.23	1.10	0.61
66	0.00	0.00	0.05	0.29	0.86	1.15	1.04	0.56	0.06	0.16	0.62	1.29	0.86	1.15	1.04	0.56
68	0.00	0.00	0.02	0.21	0.79	1.04	0.97	0.51	0.06	0.15	0.60	1.22	0.79	1.04	0.97	0.51
70	0.00	0.00	0.00	0.13	0.73	0.92	0.90	0.46	0.06	0.14	0.57	1.14	0.73	0.92	0.90	0.46
72	0.00	0.00	0.00	0.05	0.66	0.78	0.83	0.41	0.06	0.13	0.55	1.06	0.66	0.78	0.83	0.41



DOUBLE WALL ROUND

Fittings and Accessories

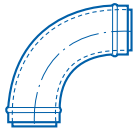

90° Pressed Elbow

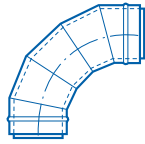

90° 5-Piece Elbow

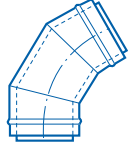

60° 3-Piece Elbow

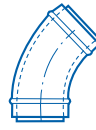

45° Pressed Elbow

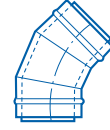

45° 3-Piece Elbow

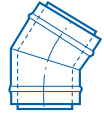

22½° and 30° 2-Pc. Elbow

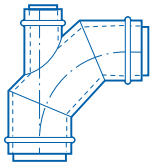

90° 3-Pc. Elbow with Heel Tap

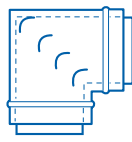

90° Mitered Elbow



45° 3-Piece Elbow with Reducer

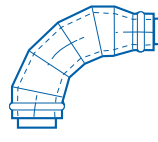

90° 5-Piece Elbow with Reducer

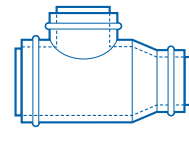

Reducing Tee

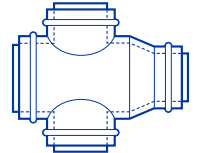

Reducing Tee Cross

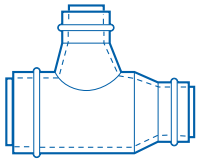

Reducing Conical Tee

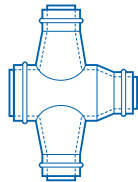

Reducing Conical Cross

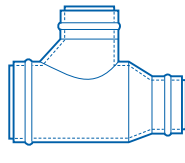

Reducing Conical Tee

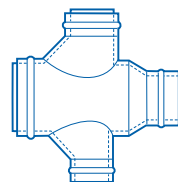

Reducing Combination Cross

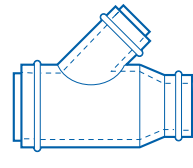

Reducing Lateral 45°

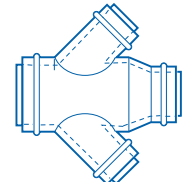

Reducing 45° Lateral Cross

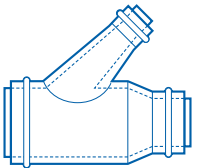

Reducing Conical 45° Lateral

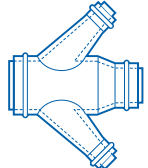

Reducing Conical 45° Lateral Cross

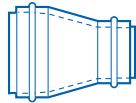

Concentric Reducer

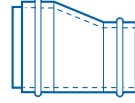

Eccentric Reducer



Pipe Coupling



Fitting Coupling



Insulation Stop



End Cap

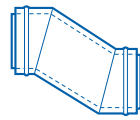

30° Offset

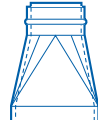

Rectangle to Round

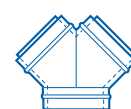

Wye



Reducing Wye



Reducing Bullhead Tee

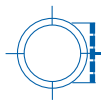

Rectangular Access Section

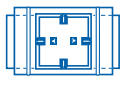

Pressed Bellmouth

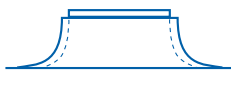

Spun Bellmouth



Shop/Field Installed Tap



Shop/Field Installed Conical Tap



Shop/Field Installed Lateral Tap

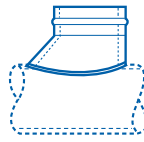

Shop/Field Installed Combination Tap

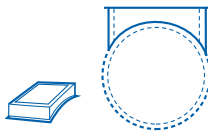

Shop/Field Installed Rectangle on Round



Field Installed Standard Door